

# Parrot UNIKA for Peugeot cars

Parrot UNIKA is a universal interface that allows you to control the Parrot RKi8400 directly with the OEM steering wheel commands. Parrot UNIKA can work with car protocols such as CAN, KBUS or resistive systems.

## Installation

### Compatibility Car models

Peugeot 207: > 2006

Peugeot 307: > 2006

Peugeot 407: > 2006

Peugeot 308: > 2007



### Parrot reference

For Parrot RKi8400

Parrot UNIKA : **PI090020AB**



# Installation

## Installation of the Parrot RKi

We recommend you to install the Parrot RKi before installing the UNIKA. Make sure the installation is correctly performed by checking if the «Good bye» message is displayed when you turn off the ignition.

► *Refer to the documentation of your Parrot RKi for more information.*

## Selecting the protocol

Use the DIP switches located on one side of the UNIKA to select the protocol (resistive or CAN Bus / KBus) on which the vehicle is based.

**Warning:** *Make sure the UNIKA is not powered before selecting the protocol.*

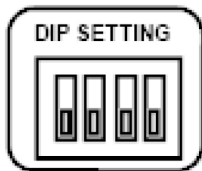

For your car set the DIP this way.

## Installing the UNIKA with the Parrot RKi8400

- Replace the MKi part on the UNIKA cable by the provided RKi part.
- Connect the UNIKA between the Parrot RKi8400 and the vehicle wiring.

**Warning :** *Connect the ignition to the Parrot car kit if the vehicle is based on a resistive or a K-Bus protocol. Don't connect the ignition if the vehicle is based on a CAN protocol as this signal is supplied by the Parrot UNIKA.*

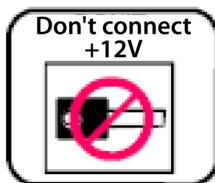

12V ignition is provided by CAN protocol

---

# CAN / KBus protocol

The wires corresponding to the CAN / KBUS protocol must be connected correctly to your car stereo's. It is important to follow the wiring diagram for your vehicle.

**Defining the mode** If your vehicle is based on a CAN Bus or KBus protocol, the mode (A, B, C or D) is automatically defined. The LED blinks in red and turns green once the mode is defined.

**Checking the wiring** Once your UNIKA interface has been fitted, the LED should light up green and should turn amber while pressing a button on your steering wheel. If the LED does not light up, check the power supply connections. If the LED is red or blinks red, check the CAN wire connections.

***Warning : Once the installation is complete, turn the ignition off until the UNIKA LED switches off.***

**Reset procedure** In case of problem or if you have installed the UNIKA interface in another car, reset the UNIKA by holding down the Reset button until the LED turns off (if the vehicle is based on a CAN Bus / KBus protocol) or blinks red (resistive protocol). You can then release the reset button.

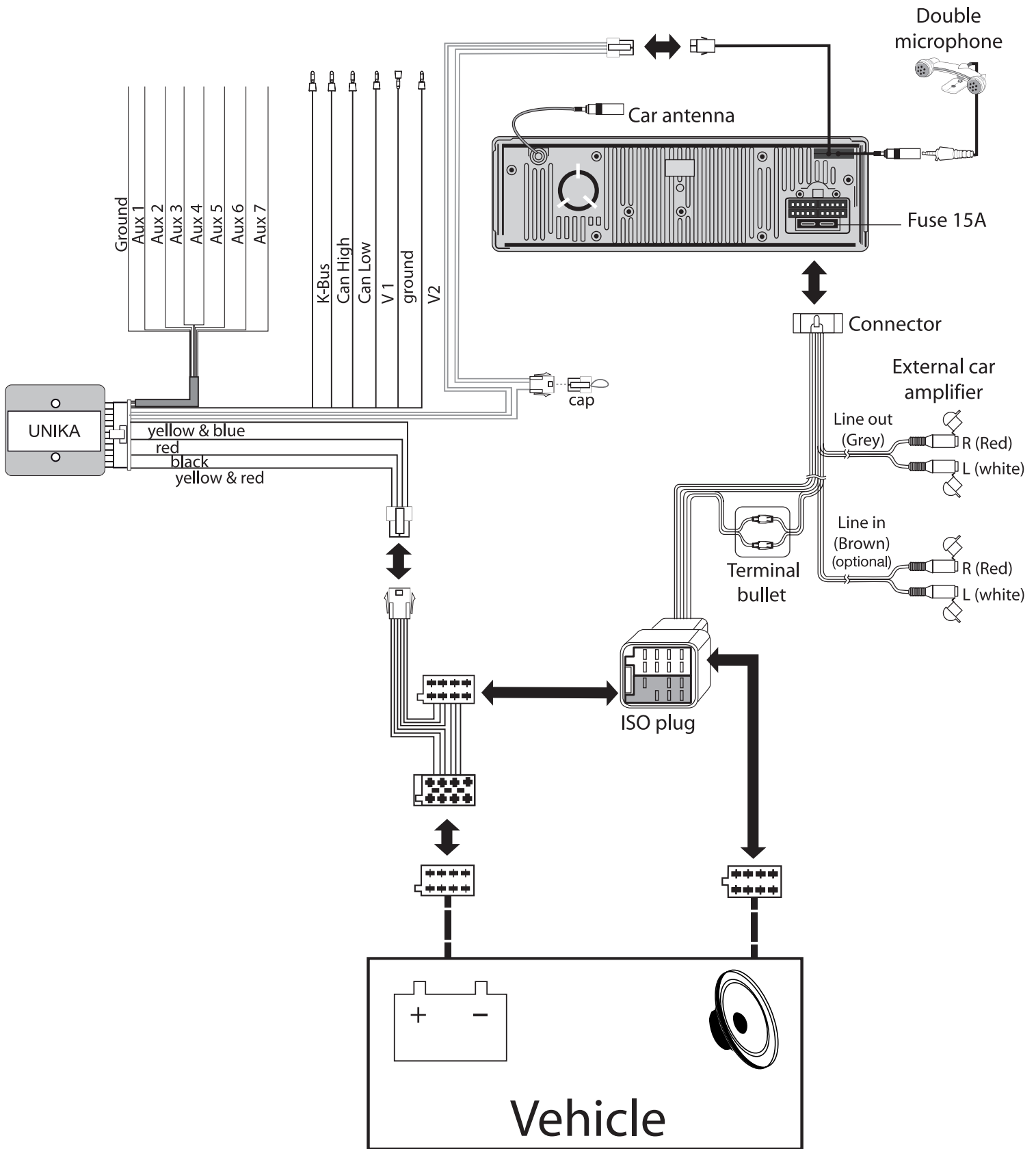

## CAN Configuration Peugeot

The wires corresponding to the CAN protocol must be connected correctly to your car stereo's CAN information. It is important to follow the wiring diagram for your vehicle. We would advise our customers to have the interface fitted by a professional.

| N°       |  | Color  | Description |
|----------|--|--------|-------------|
| 10       |  | Green  | CAN High    |
| 13       |  | White  | CAN Low     |
| Not used |  | Violet | K-BUS       |

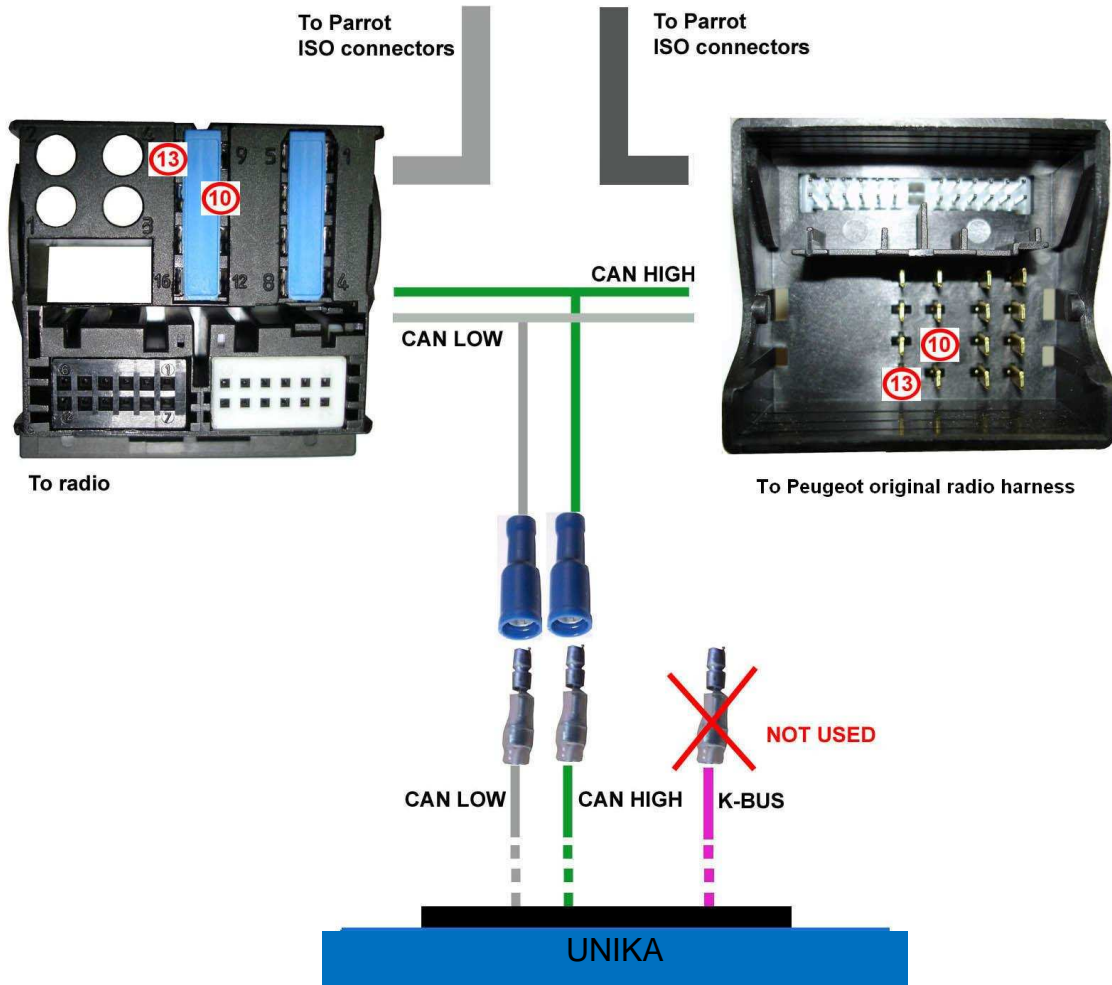

Connect the green wire corresponding to CAN High to pin 10.  
Connect the white wire corresponding to CAN Low to pin 13.

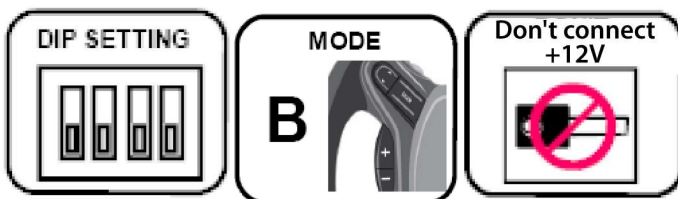

---

# Programming Parrot UNIKA for your car

*The wires corresponding to the CAN / KBUS protocol must be connected correctly to your car stereo's. It is important to follow the wiring diagram for your vehicle.*

## Defining the mode

If your vehicle is based on a CAN Bus or KBus protocol, the mode (A, B, C or D) is automatically defined. The LED blinks in red and turns green once the mode is defined.

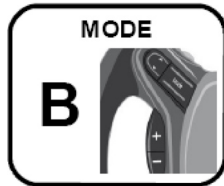

Your system runs on B mode.

## Checking the wiring

Once your UNIKA interface has been fitted, the LED should light up green and should turn amber while pressing a button on your steering wheel. If the LED does not light up, check the power supply connections. If the LED is red or blinks red, check the CAN wire connections.

---

## 2 - Features

Depending on the steering wheel control in your vehicle, the UNIKA interface will enable you to take full advantage of the telephone and music functions in 4 different modes: Mode A (4 buttons), Mode B (5 buttons), Mode C (6 buttons) and Mode D (7 buttons). The selection of this mode depends on the protocol of the vehicle.

*Note : Pictograms on the buttons depend on the model of the vehicles.*



Short press



2 short presses



Long press



Volume



Seek









Source



Pick up - Hang up

---

**Warning :** *The mode you will use depends on the number of available buttons and not on the pictograms. For instance, if you have the      buttons, you will use the UNIKA in mode B : consider the  button is replaced by the  button.*

# Mode B



Adjust the volume / Modifier le volume / Ajustar el volumen / Einstellung der Lautstärke / Modificare il volume / De geluidsterkte regelen



Answer an incoming call / Répondre à un appel / Descolgar una llamada / Entgegennehmen eines eingehenden Anrufs / Rispondere a una chiamata / Een inkomend gesprek opnemen



Refuse an incoming call / Refuser un appel / Colgar una llamada / Beenden eines eingehenden Anrufs / Rifiutare una chiamata / en inkomend gesprek weigeren



Hang up / Raccrocher / Rechazar / Ablehnen / Riagganciare / Ophangen



Redial function / Fonction Bis / Función de rellamada / Wiederholung des letzten Anrufs / Funzione Bis / Bis functie



Next - previous / Suivant - précédent / Siguiente - precedente / Vorhergehende - nächsten / Precedente - successivo



Discreet mode / Mode discret / Modo discreto / Diskreter Modus / Modalità privata / Privacy mode



Exit discreet mode / Sortir du mode discret / Salir del modo discreto / Beenden des Diskreter Modus / Disattivare la modalità privata / De discrete modus opheffen



Start the voice recognition feature / Lancer la reconnaissance vocale / Iniciar el modo de reconocimiento de voz / Aktivieren der Spracherkennung / Attivare la funzione di ricon. vocale / De modus Spraakherkenning sluiten



Selecting a music source / Sélectionner une source audio / Seleccionar una fuente de audio / Auswahl der Audioquelle / Selezionare l'audio



Next - previous / Suivant - précédent / Siguiente - precedente / Vorhergehende - nächsten / Precedente - successivo