

Parrot UNIKA for Mercedes cars

Parrot UNIKA is a universal interface that allows you to control the Parrot RKi8400 directly with the OEM steering wheel commands. Parrot UNIKA can work with car protocols such as CAN, KBUS or resistive systems.

Installation

Compatibility Actros >2007
Car models Sprinter >2007
Viano > 2006
Vito > 2006



Parrot reference

For Parrot RKi8400
Parrot UNIKA : **PI090020AB**



Installation

Installation of the Parrot RKi

We recommend you to install the Parrot RKi before installing the UNIKA. Make sure the installation is correctly performed by checking if the «Good bye» message is displayed when you turn off the ignition.

► *Refer to the documentation of your Parrot RKi for more information.*

Selecting the protocol

Use the DIP switches located on one side of the UNIKA to select the protocol (resistive or CAN Bus / KBus) on which the vehicle is based.

Warning: *Make sure the UNIKA is not powered before selecting the protocol.*

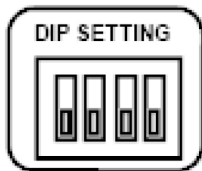

For your car set the DIP this way.

Installing the UNIKA with the Parrot RKi8400

- Replace the MKi part on the UNIKA cable by the provided RKi part.
- Connect the UNIKA between the Parrot RKi8400 and the vehicle wiring.

Warning : *Connect the ignition to the Parrot car kit if the vehicle is based on a resistive or a K-Bus protocol. Don't connect the ignition if the vehicle is based on a CAN protocol as this signal is supplied by the Parrot UNIKA.*

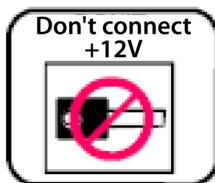

12V ignition is provided by CAN protocol

CAN / KBus protocol

The wires corresponding to the CAN / KBUS protocol must be connected correctly to your car stereo's. It is important to follow the wiring diagram for your vehicle.

Defining the mode If your vehicle is based on a CAN Bus or KBus protocol, the mode (A, B, C or D) is automatically defined. The LED blinks in red and turns green once the mode is defined.

Checking the wiring Once your UNIKA interface has been fitted, the LED should light up green and should turn amber while pressing a button on your steering wheel. If the LED does not light up, check the power supply connections. If the LED is red or blinks red, check the CAN wire connections.

Warning : Once the installation is complete, turn the ignition off until the UNIKA LED switches off.

Reset procedure In case of problem or if you have installed the UNIKA interface in another car, reset the UNIKA by holding down the Reset button until the LED turns off (if the vehicle is based on a CAN Bus / KBus protocol) or blinks red (resistive protocol). You can then release the reset button.

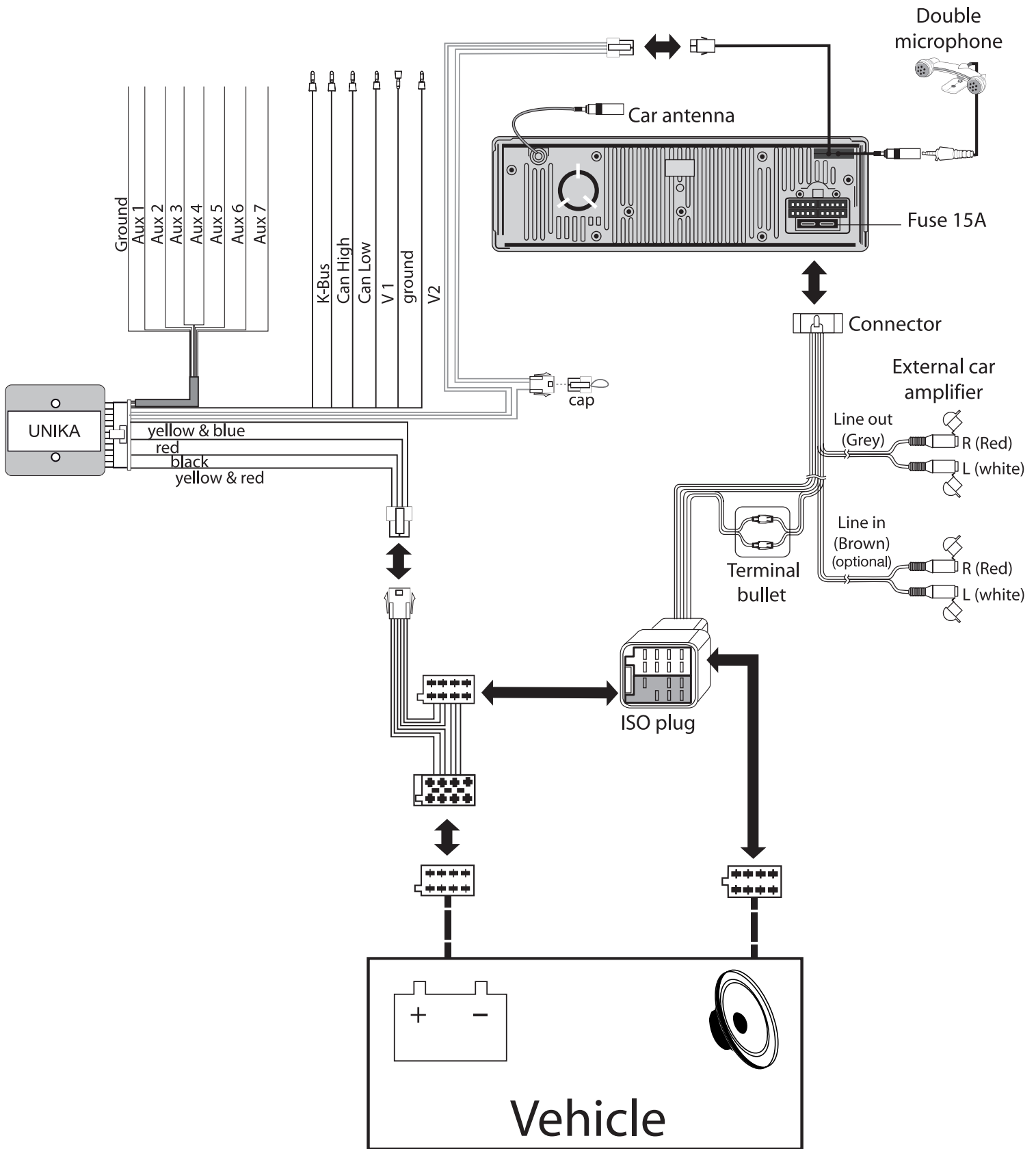

CAN Configuration Mercedes

The wires corresponding to the CAN protocol must be connected correctly to your car stereo's CAN information. It is important to follow the wiring diagram for your vehicle. We would advise our customers to have the interface fitted by a professional.

N°		Color	Description
22		Green	CAN High
17		White	CAN Low
Not used		Violet	K-BUS

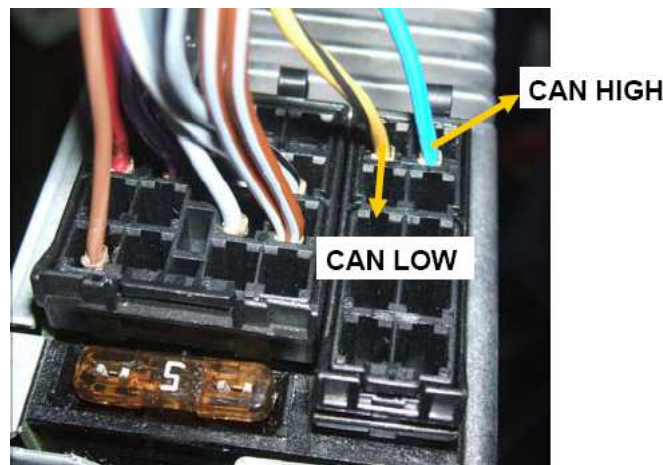
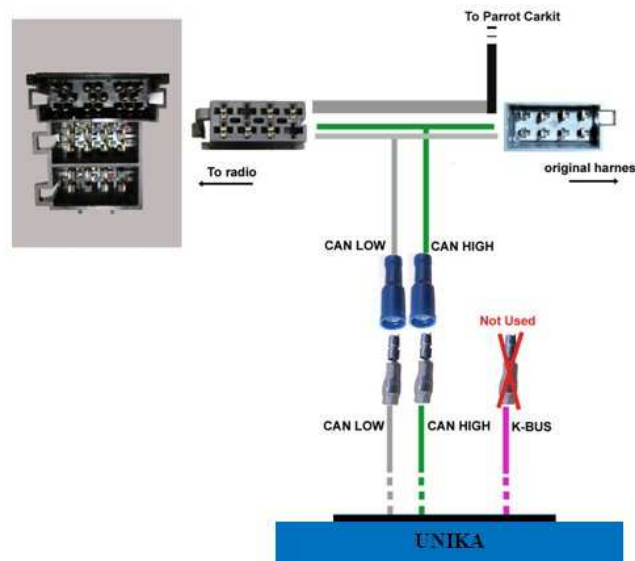

Connect the white wire corresponding to CAN Low to Yellow/ Black wire. Pin 17.
Connect the green wire corresponding to CAN High to the blue wire. Pin 22

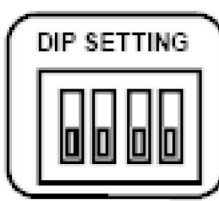
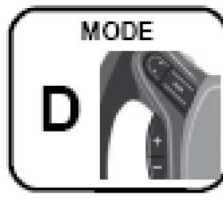
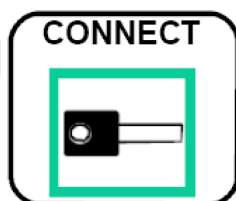

Programming Parrot UNIKA for your car

The wires corresponding to the CAN / KBUS protocol must be connected correctly to your car stereo's. It is important to follow the wiring diagram for your vehicle.

Defining the mode

If your vehicle is based on a CAN Bus or KBus protocol, the mode (A, B, C or D) is automatically defined. The LED blinks in red and turns green once the mode is defined.

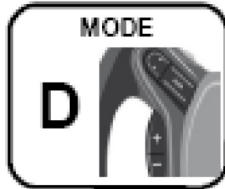

Your system runs on D mode.

Checking the wiring

Once your UNIKA interface has been fitted, the LED should light up green and should turn amber while pressing a button on your steering wheel. If the LED does not light up, check the power supply connections. If the LED is red or blinks red, check the CAN wire connections.

2 - Features

Depending on the steering wheel control in your vehicle, the UNIKA interface will enable you to take full advantage of the telephone and music functions in 4 different modes: Mode A (4 buttons), Mode B (5 buttons), Mode C (6 buttons) and Mode D (7 buttons). The selection of this mode depends on the protocol of the vehicle.

Note : Pictograms on the buttons depend on the model of the vehicles.



Short press



2 short presses



Long press



Volume









Seek



Source



Pick up - Hang up

Warning : *The mode you will use depends on the number of available buttons and not on the pictograms. For instance, if you have the      buttons, you will use the UNIKA in mode B : consider the  button is replaced by the  button.*

Mode D



Enter the menu / Entrer dans le menu / Entrar en el menú / Öffnen eines Menüs / Accedere al menu / Het hoofdmenu openen



Navigate through the menus / Naviguer dans le menu / Navegar por los menús / Navigation in den Menüs / Consente di utilizzare i menu / In de menu's navigeren



Confirm menu choice / Confirmer / Validar la selección / Bestätigung einer Auswahl / Confermare la selezione / De selectie valideren



Back menu / Menu précédent / Menú anterior / Rückkehr zum vorhergehenden Menü / Consente di tornare al menu precedente / Vorige menu



Adjust the volume / Modifier le volume / Ajustar el volumen / Einstellung der Lautstärke / Modificare il volume / De geluidssterkte regelen



Answer an incoming call / Répondre à un appel / Descolgar una llamada / Entgegennehmen eines eingehenden Anrufs / Rispondere a una chiamata / Een inkomend gesprek opnemen



Refuse an incoming call / Refuser un appel / Colgar una llamada / Beenden eines eingehenden Anrufs / Rifiutare una chiamata / en inkomend gesprek weigeren



Hang up / Raccrocher / Rechazar / Ablehnen / Riagganciare / Ophangen



Discreet mode / Mode discret / Modo discreto / Diskreter Modus / Modalità privata / Privacy modus



Exit discreet mode / Sortir du mode discret / Salir del modo discreto / Beenden des Diskreter Modus / Disattivare la modalità privata / De discrete modus opheffen



Start the voice recognition feature / Lancer la reconnaissance vocale / Iniciar el modo de reconocimiento de voz / Aktivieren der Spracherkennung / Attivare la funzione di ricon. vocale / De modus Spraakherkenning sluiten



Redial function / Fonction Bis / Función de rellamada / Wiederholung des letzten Anrufs / Funzione Bis / Bis functie



Mute Mic / Couper le microphone / Desactivar el micrófono / Das Mikrophon deaktivieren / Disattivare il microfono / De microfoon in- of uitschakelen



Next - previous / Suivant - précédent / Siguiente - precedente / Vorhergehende - nächsten / Precedente - successivo



Play - Pause / Parar - reproducir música / Anhalten - Fortsetzen der Wiedergabe / Interrompere - riprendere la lettura